

The **Smith Meter™ Model SD-30-DI (Ductile Iron) and SD3-SI (Steel) Meters** are 3", Class 150 ANSI, R.F. Flange, single-case, rotary vane, positive displacement meters. Applications include: blending, batching, dispensing, inventory control, and custody transfer of oils, solvents, chemicals, paints, fats, and fertilizers.

Features

- **Superior Accuracy** - The Smith Meter™ Rotary Vane Meter principle, combined with the meter's uniquely designed (offset) inlet and outlet nozzles, minimizes pressure drop across the measuring chamber, which reduces flow through meter clearances to maximize accuracy.
- **Low Pressure Drop** - Streamlined flow path provides low pressure drop.
- **Positive and Accurate Registration** - High torque drive calibrator with adjustment in 0.05% increments ensures accurate registration.
- **Long Service Life** - Low friction ball bearings, fixed cam-type timing, and rugged construction give sustained accuracy and long service life.

Options

- **High Viscosity Meter Clearances** - To extend operation at maximum flow rate from 400 mPa•s to 2,000 mPa•s.
- **High Temperature Clearances** - To extend operating temperatures from 150°F to 200°F (65°C to 93°C).
- **All Iron Trim** - For operating temperatures above 200°F (93°C).

Specifications

Maximum Flow Rate

	USGPM	L/min
Continuous Rating - Standard Trim	320	1,200
Intermittent Rating ¹ - Standard Trim	400	1,500
Continuous/Intermittent Rating - All Iron Trim	240	900

¹ Intermittent Rating applies to service on clean, refined products where continuous operation is not required (e.g., truck loading, rail loading, and other batching applications).

² Based on a maximum flow rate of 320 USGPM (1,200 L/min).

³ Based on a maximum of 250 USGPM (950 L/min).

⁴ 1,000 mPa•s = 1,000 cP = 1 Pa•s.

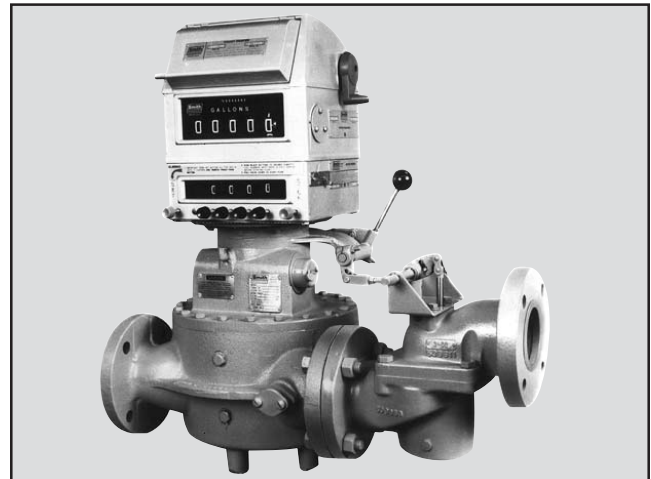

3" Meter with Mechanical Preset Package

Minimum Flow Rate — Typical Performance

Linearity ²	Units	Viscosity (mPa•s)					
		0.5	1	5	20	100	400
±0.15%	USGPM	50 ³	30	12	3.0	0.60	0.15
	L/min	190 ³	113	45	11.3	2.30	0.57
±0.25%	USGPM	40	22	9	2.2	0.45	0.11
	L/min	150	83	34	8.3	1.70	0.42
±0.50%	USGPM	25	15	6	1.5	0.30	0.08
	L/min	95	57	23	5.7	1.10	0.30

Repeatability

±0.02%

Viscosity

Standard: 400 mPa•s⁴ (2,000 SSU) maximum.

Optional: 2 Pa•s (10,000 SSU) maximum - specify "High Viscosity Meter Clearances."

Over 2 Pa•s - Specify "High Viscosity Meter Clearances" and derate maximum flow rate in direct proportion to viscosity over 2 Pa•s (e.g., at 4 Pa•s, derate maximum flow rate to 50% of normal continuous rating - 160 USGPM).

Temperature

Standard Meter Clearances With:

Buna

Viton: 10°F to 150°F (-12°C to 65°C).

Teflon: -20°F to 150°F (-29°C to 65°C).

High Temperature Meter Clearances With:

Buna

Viton: 10°F to 200°F (-12°C to 93°C).

Teflon: -20°F to 200°F (-29°C to 93°C).

All Iron Trim With:

Buna

Viton: 10°F to 300°F (-12°C to 149°C).

Teflon: -20°F to 300°F (-29°C to 149°C).

Maximum Working Pressure

Standard: 150 psig (1,034 kPa) up to 200°F (93°C).

Meter Gearing

5 U.S. Gallons or 1 Dekalitre per revolution of meter calibrator output shaft.

Pressure Drop (ΔP)

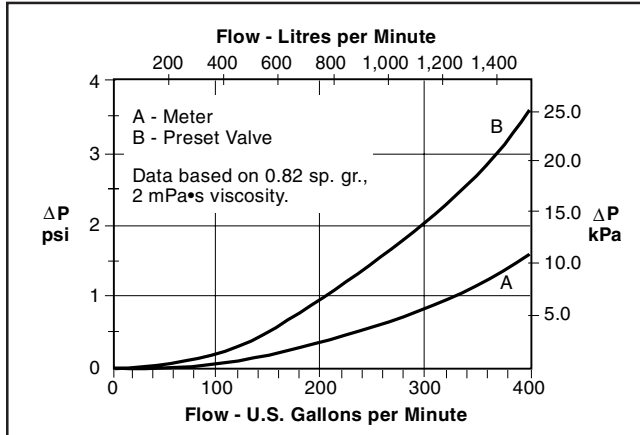

Materials of Construction

	Housing	Internals	Seals
Meter With Standard Trim	Ductile Iron or Steel	Iron, Steel, Stainless Steel, Aluminum	Loctite Master Gasket ⁵ and Packing Gland Std. - Buna Opt'l. - Teflon and Viton
Meter With All Iron Trim	Ductile Iron	Delete Aluminum From Standard	
Set-Stop Valve Offset Type	Ductile Iron	Steel, Iron, Ni-Resist	Std. - Buna N Opt'l. - Viton EPR, or Teflon
Straight Through Type	Steel		

Installation

It is recommended that the meter be protected with a 40 mesh strainer.

Dimensions

Inches (mm)

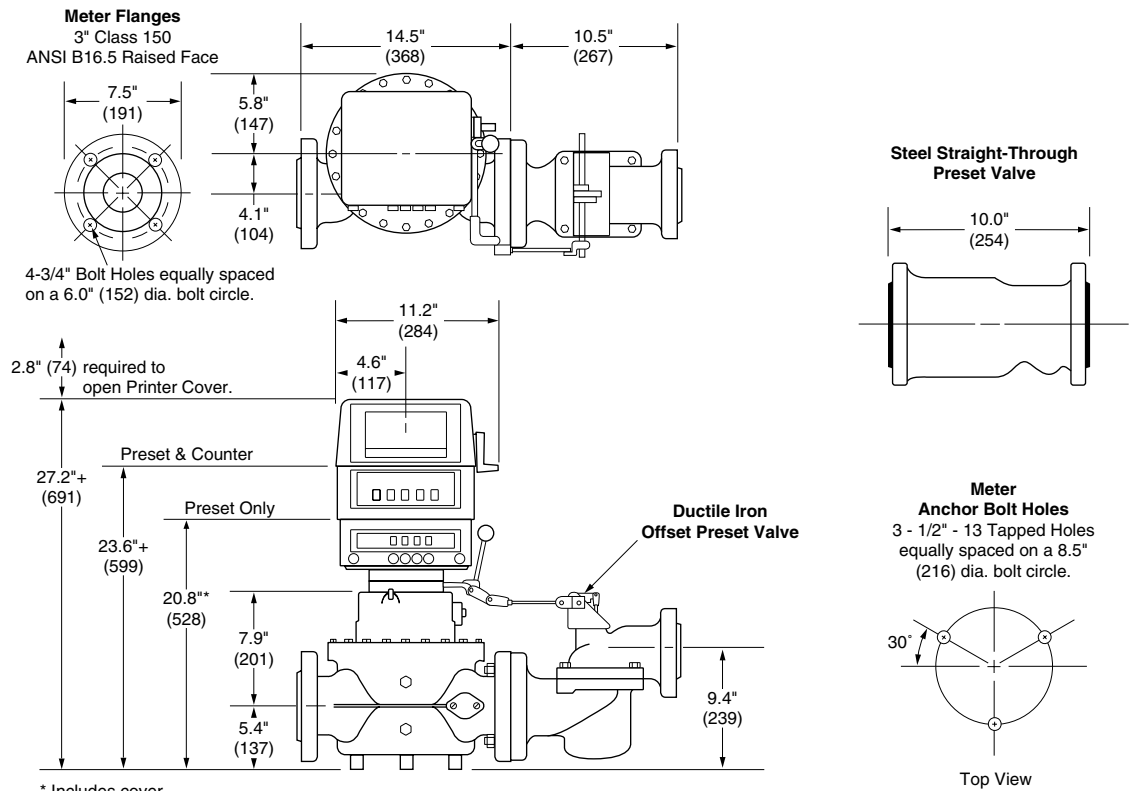

Note: Dimensions — Inches to the nearest tenth (millimetres to the nearest whole mm), each independently dimensioned from respective engineering drawings.

	Lb	Kg
Meter	183	83
Meter/LNC+	198	90
Preset Package+*	259	117

+Add 10 lb (4.5 kg) if ticket printer is required.
+Includes Meter, LNC, Preset counter and Valve.

⁵ For other than petroleum applications, consult factory.

Ordering Information

Application	Batching, Loading, Blending, Inventory, Process Control, etc.
Operating Conditions	Liquid — Name and sp. gr., Flow Range ⁶ , Temp. Range ⁶ , Viscosity Range ⁶ , Maximum Working Pressure.
Seals	Packing Gland: Buna ⁷ , Viton or Teflon. Valve: Buna ⁷ , Viton, EPR, or Teflon.
Units of Registration	Gallons, Litres, Pounds, Kilograms.
Direction of Flow	Left-to-right flow (as viewed above) is standard and will be supplied unless right-to-left flow is specified.
Options & Accessories	As required.

Accessories

Strainer

3" Model S3-1-ST basket-type, 3" steel, with Class 150 ANSI R.F. Flanges.

Air Eliminator

Model AR3-1030-1, 3" Steel, Class 150 ANSI R.F. Flanges.

Mechanical Set-Stop Valves

3" offset-type, ductile iron, Class 150 ANSI R.F. Flanges.

Automatic Temperature Compensation

Model ATC - Factory-set for a given product.

Model ATG - Field-adjustable for different products.

Counters

200 Series - Accumulative, nine-digit, non-reset type.

600 Series - 5 large-digit reset, eight small-digit non-reset.

Printer

Seven-digit accumulative.

Optional six-digit zero start.

Preset Counter

300C Series - Four-digit (five-digit optional) mechanical pushbutton preset with microswitch package for valve or pump control.

Pulse Transmitters

Type E - SPDT Mercury Wetted Switch.

LNC Pulse Transmitter (adapts to 600 Series Counters).

Low-Resolution - 1 or 10 pulses⁷.

High-Resolution (HR) - 50 or 100 pulses⁷.

PST - Dual-channel, high-resolution, security pulse generator.

UPT - Universal Pulse Transmitter - High resolution dual pulse quadrature output in a weather-tight explosion-proof enclosure (up to 1,000 pulses/rev.).

Flow Rate Indicator

Direct mount mechanical.

Remote electronic.

Remote Registration

Electromechanical counters.

Electronic totalizers.

⁶ Specify: minimum/normal/maximum.

⁷ Standard seals supplied unless optional material specified.

⁸ Per revolution of LNC right-hand wheel.

Revisions included in SS01007 Issue/Rev. 0.7 (1/06):
Page 2: Corrected pounds to kilogram conversion dimension.

The specifications contained herein are subject to change without notice and any user of said specifications should verify from the manufacturer that the specifications are currently in effect. Otherwise, the manufacturer assumes no responsibility for the use of specifications which may have been changed and are no longer in effect.

Headquarters:

1803 Gears Road, Houston, TX 77067 USA, Phone: 281/260-2190, Fax: 281/260-2191

Gas Measurement Products:

Houston, TX USA Phone 281/260-2190
Thetford, England Phone (44) 1842-82-2900
Kongsberg, Norway Phone (47) 32/286-700
Buenos Aires, Argentina Phone 54 (11) 4312-4736

Integrated Measurement Systems:

Corpus Christi, TX USA Phone 361/289-3400
Kongsberg, Norway Phone (47) 32/286-700
San Juan, Puerto Rico Phone 787/274-3760
United Arab Emirates, Dubai Phone 971 +4/331-3646

Liquid Measurement Products:

Erie, PA USA Phone 814/898-5000
Los Angeles, CA USA Phone 661/702-8660
Slough, England Phone (44) 1753-57-1515
Ellerbek, Germany Phone (49) 4101-3040
Barcelona, Spain Phone (34) 93/201-0989
Moscow, Russia Phone (7) 495/564-8705
Melbourne, Australia Phone (61) 3/9807-2818

Beijing, China Phone (86) 10/6500-2251
Singapore Phone (65) 6861-3011
Chennai, India Phone (91) 44/450-4400

Visit our website at www.fmctechnologies.com